

Alternate Orientations/Driver Mounting

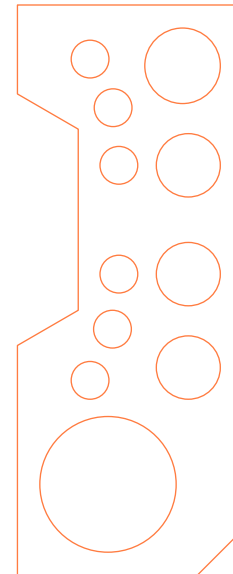

Notes:

- o/ A classic Golden Ratio based derivative of the Mar-KenP7 designed for Mark Audio Pluvia Seven
- 1/ to be built as mirror imaged pairs – drivers are mounted off-centre (based on the golden ratio)
- 2/ All panels 15mm
- 3/ Vents are 15mm high, vent spacer is 60mm wide and centrally located
- 4/ brace shape is only suggestive – prime purpose is to brace driver, it needs to be about 35-40% holes. (ie if you have to mount a terminal cup in the middle, you'll want to make sure the brace allows clearance), It is centrally mounted on the driver magnet
- 5/ Don't forget to angle cut the back of the driver cut-out to give it breathing room
- 6/ All internal panels lined with ~1/2" (12mm) cotton or wool felt (preferred), 3/4" (19mm) poly-fluff batting, or 1" (25mm) fiberglass Note that it is hard to get into the box after it is sealed up (means terminals need to be solderable from outside the box as well)

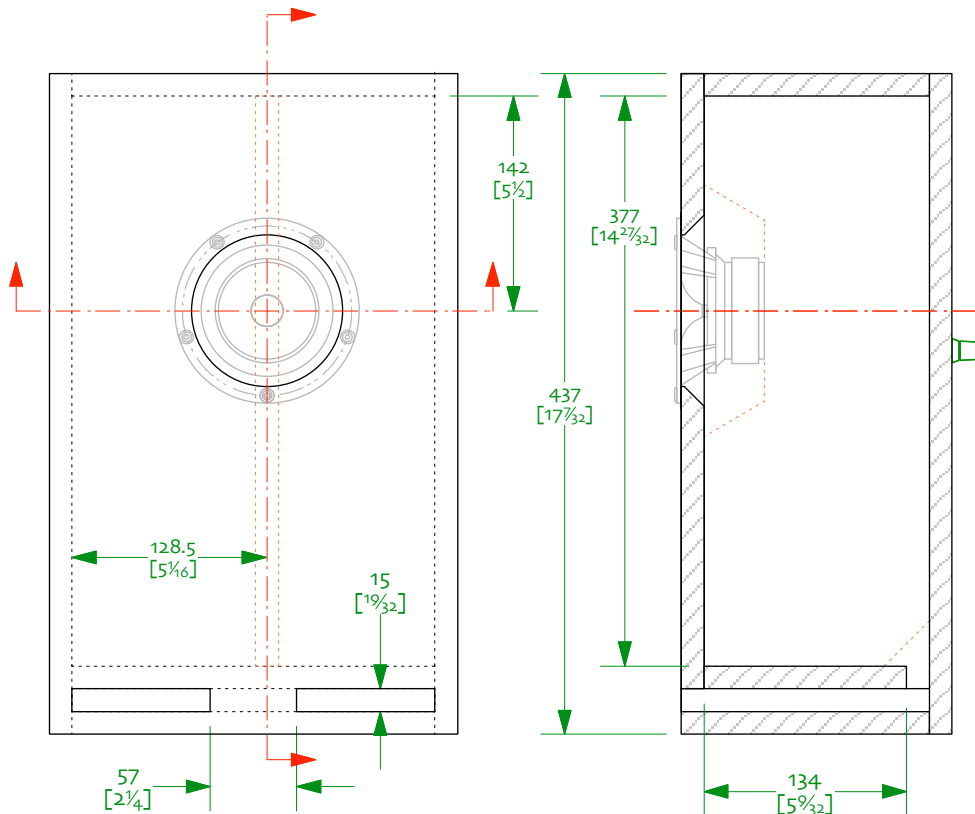

Classic GR Mar-KenP7 ov90

sheet cgrmkp715w | 15mm plan
 © 2011-2016 planet_10 enterprises limited
 03- february-2016| designed & drawn by did
 free for non-commercial use only