

Notes:

This driver comes as 3 separate pieces

- 1/ driver
- 2/ second magnet with magnet cover
- 3/ bezel cover

These can be assembled into 4 configurations of the driver. Individual drawings of each possible configuration are on the next sheet

Drivers come with second magnet attached and bezel cover fitted but not glues/

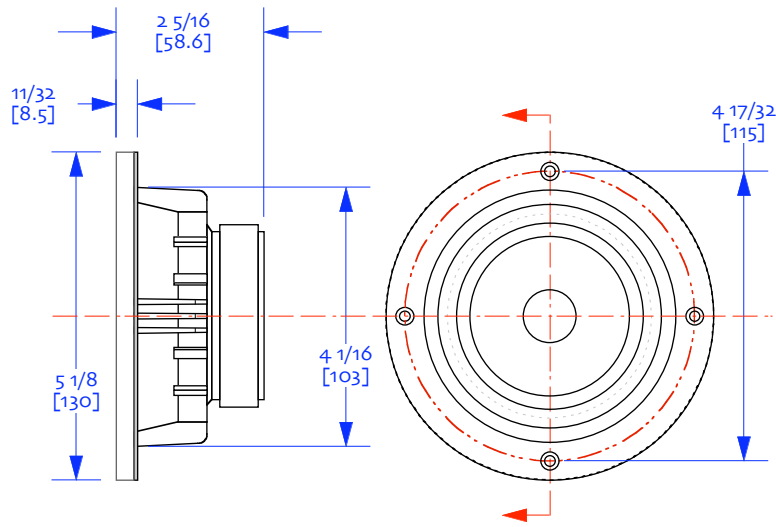

A: 1 magnet / no bezel cover

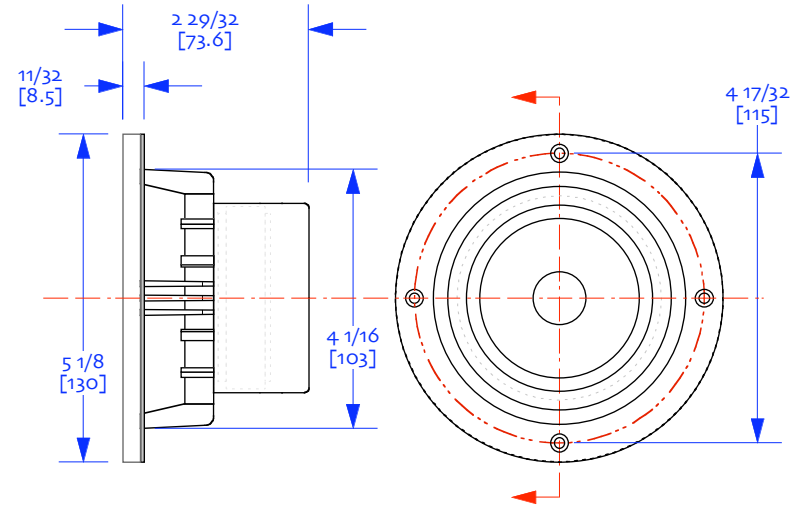

B: 2 magnets / no bezel cover

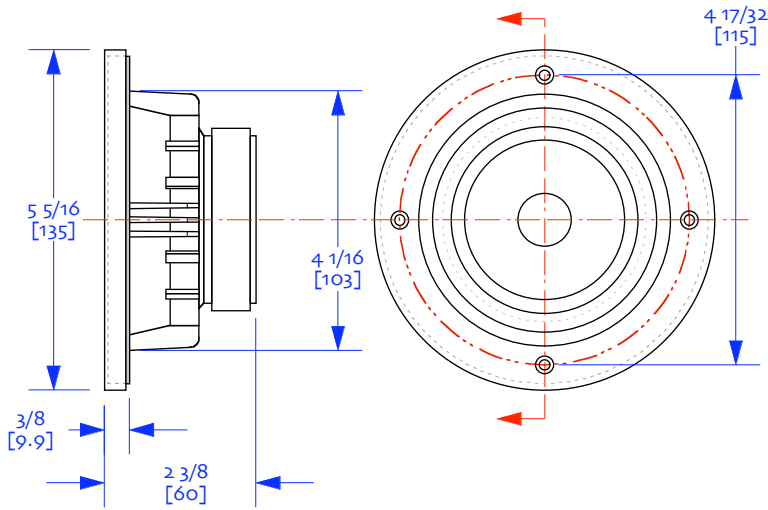

C: 1 magnet / bezel cover

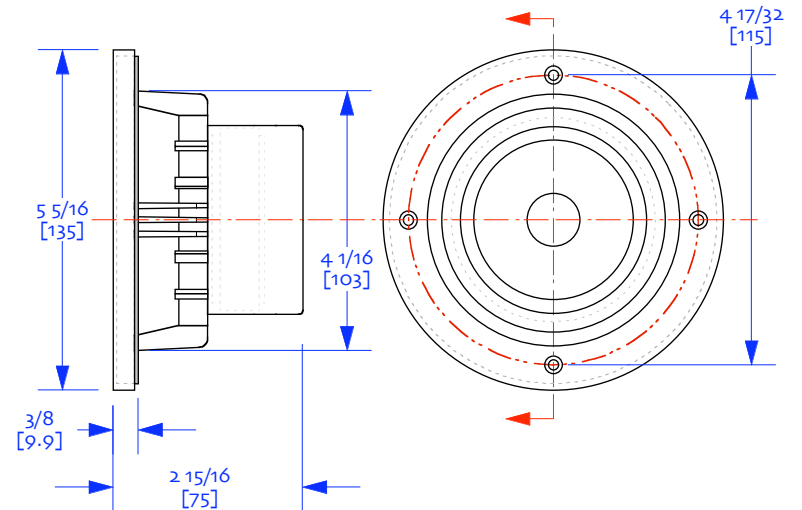

D: 2 magnets / bezel cover



Alpair 7.3
 4 possibilities
 driver dimensions
 drawn by did | 23-june-2011