



Alpair 5 Gen. 2

The Alpair 5 Generation 2 is a pure *Free-to-air* Single Suspension Full-Range audio driver. This new Alpair 5 is more advanced than its first generation version. The new 5 operates only using its all-new single front suspension.

This design retains designer Mark Fenlon's classical mechanical engineering approach to reduce mass and extend long throw operating capacity. Mark, along with Evan Yu and the engineering team spent several months of research removing mechanical restriction from the ultra thin coil body. Traditional driver designs use a "spider", a suspension device located behind the driver's cone. Bonded to the coil, it physically restricts a coils ability to transfer mechanical-acoustic signals to the cone. Some other drivers use damping fluid, springs or other devices, all of which produce losses. This new Alpair 5 design completely removes all these restrictions; Its coil locates cleanly between the driver's cone and motor sub-assembly, making the new 5 a pure *free-to-air* mechanical design.

The accuracy requirement for this new Alpair 5 component design, engineering and detailed assembly goes well beyond typical commercial audio-driver manufacturing. The front suspension operating tolerance is measured in milli-newtons. Production Alpair 5 drivers are made to within +/- 2.5Hz @ F Zero. All production units are then pair matched to with +/- 1Hz @ F Zero.



The result is a detailed balanced sound representation across an ultra wide frequency band for this class of small driver. A typical box bass-reflex box application with an internal volume of 3 litres can be port tuned to below 80Hz while the driver retains is high range output up to 25kHz. The outcome is a very easy to use versatile driver suitable for many smaller applications where higher-end sound quality is desired from a mini-sized audio driver.

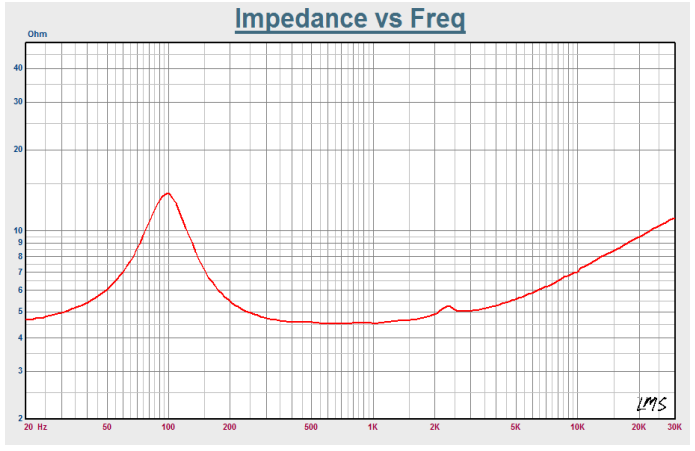
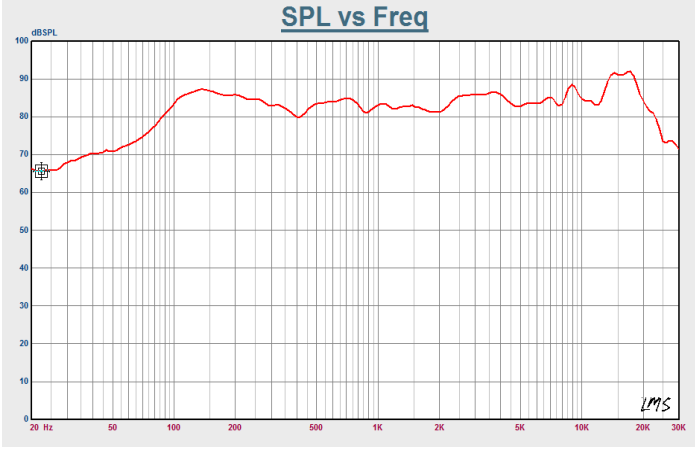

R_{vc}= 3.600 Ohm
 F_o= 101.220 Hz
 S_d= 28.270 cm²
 V_{as}= 1.324 Ltr
 C_{ms}= 1.166m M/N
 M_{md}= 1.992m Kg
 M_{ms}= 2.078 g
 B_L= 2.522 TM
 Q_{ms}= 1.493
 Q_{es}= 0.755
 Q_{ts}= 0.502
 L_{vc}= 38.886u H
 N_o= 0.181 %
 S_{PLo}= 84.593 dB
 X_{max}= 3.0mm 1 way
 P_{wr}= 15 watts peak Nom.

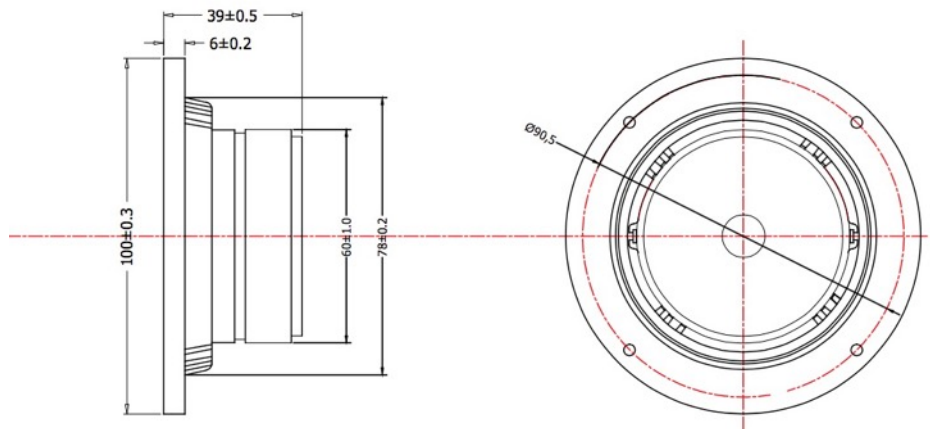

Please note this driver frame has off-set screw mounting positions